

Truck shown in test position

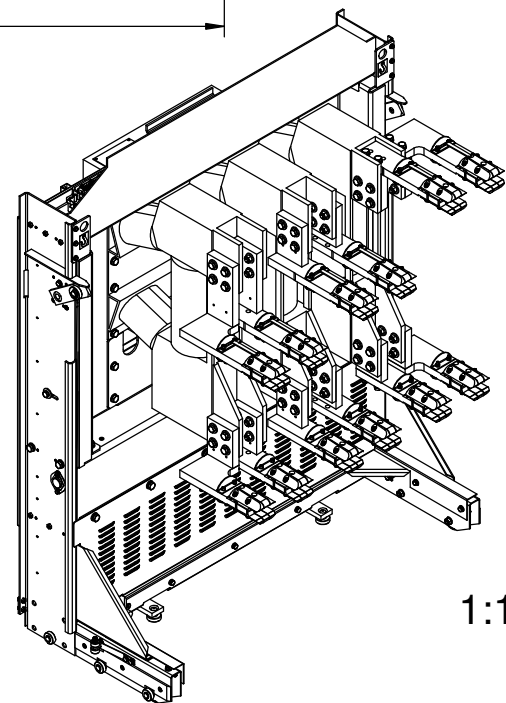

1:15

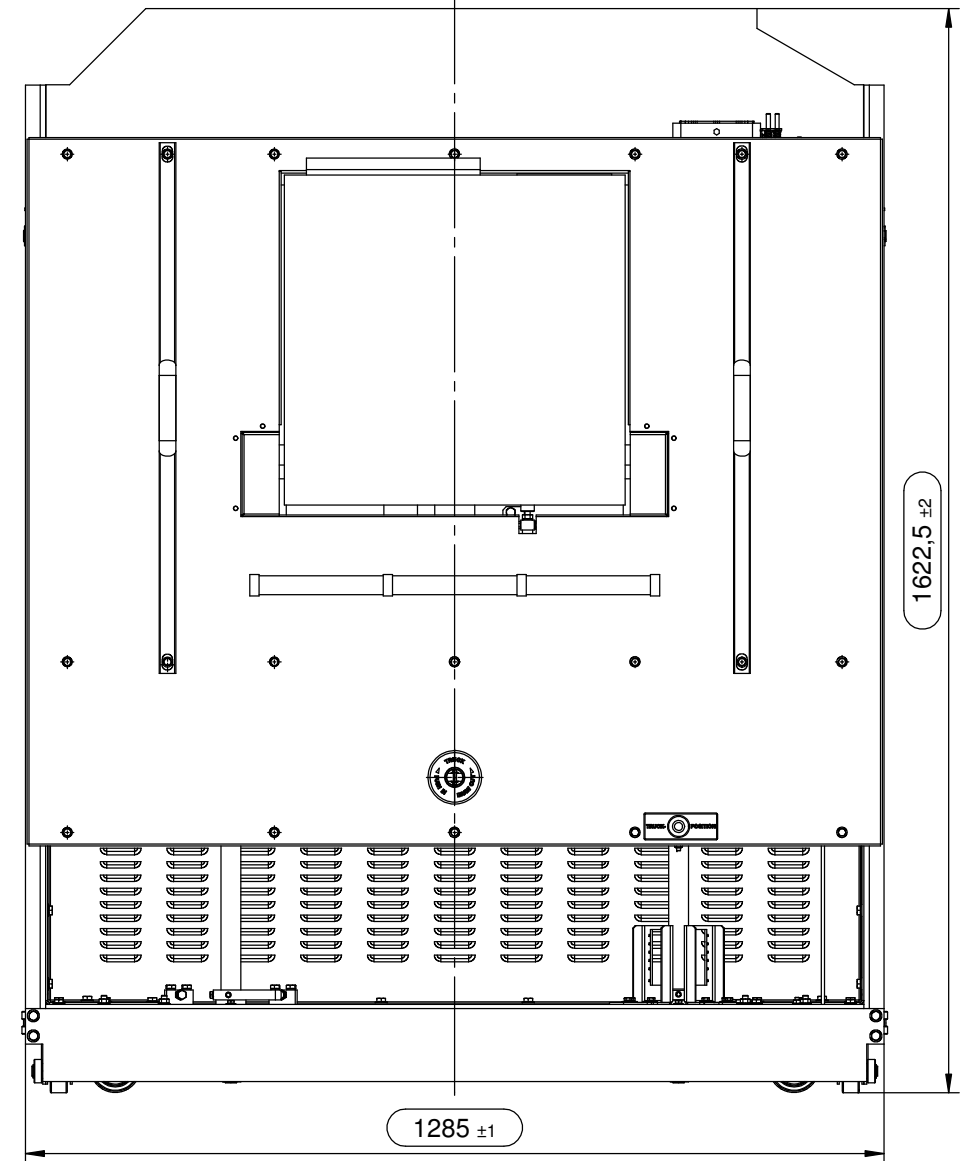
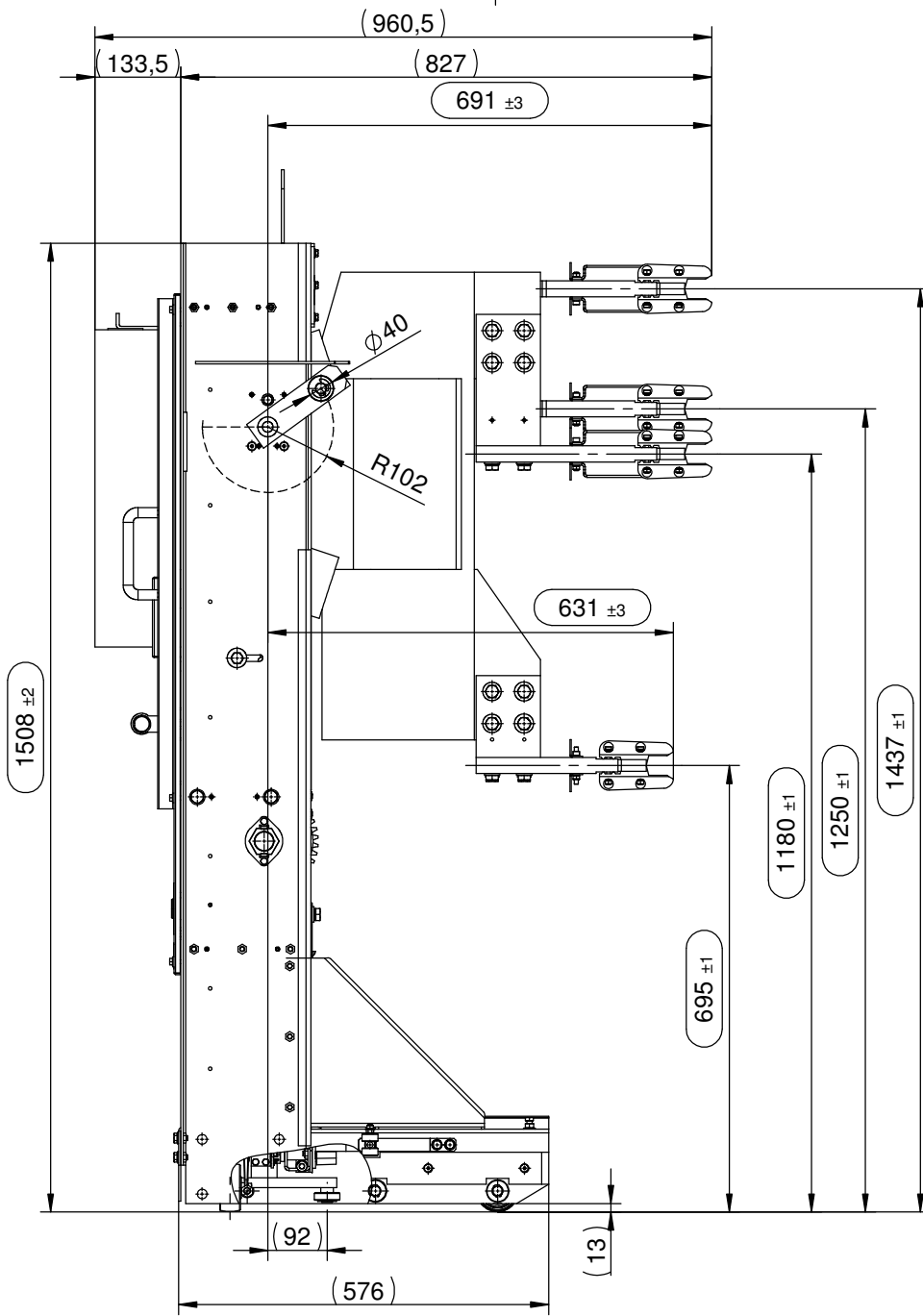
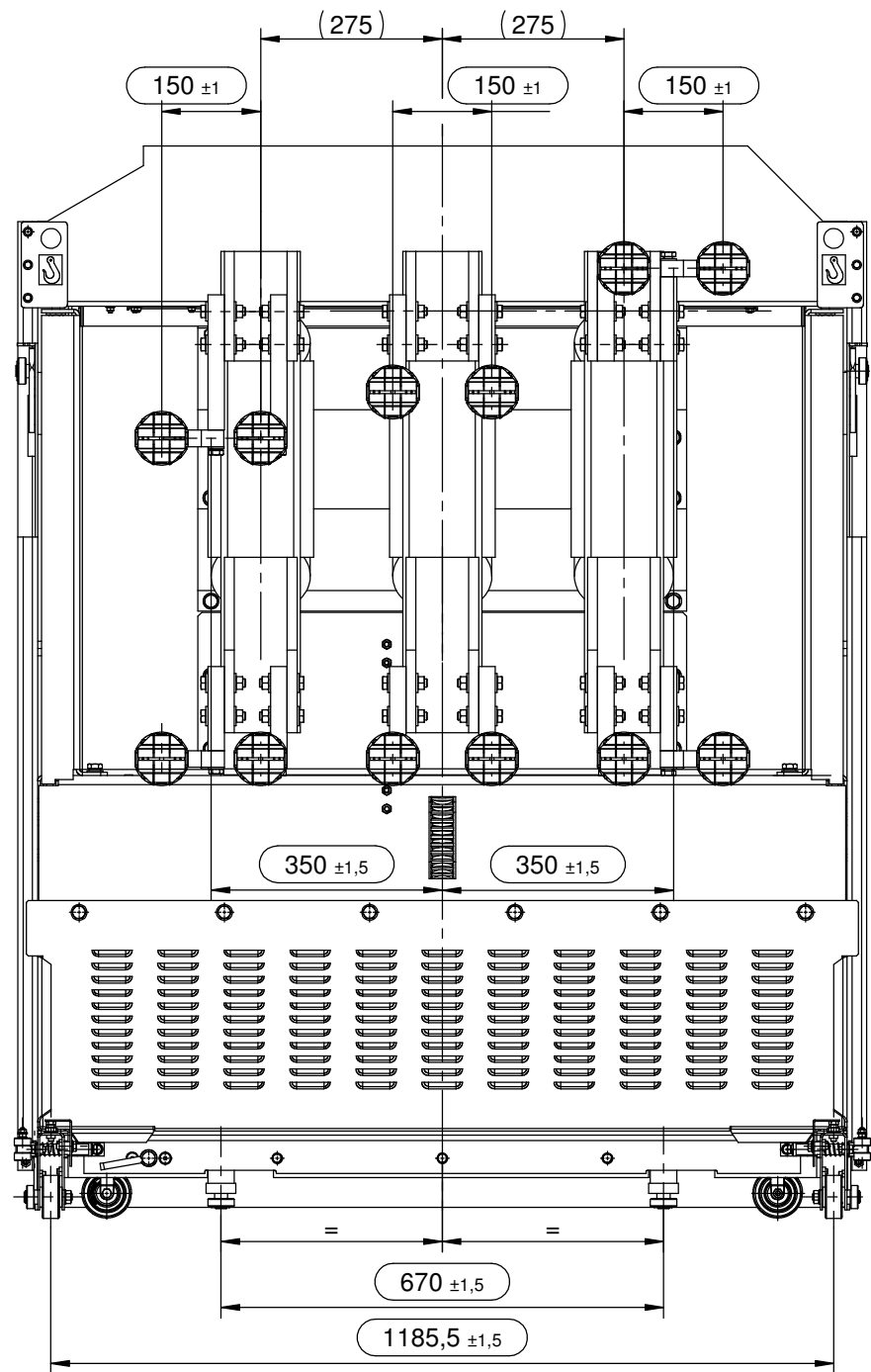
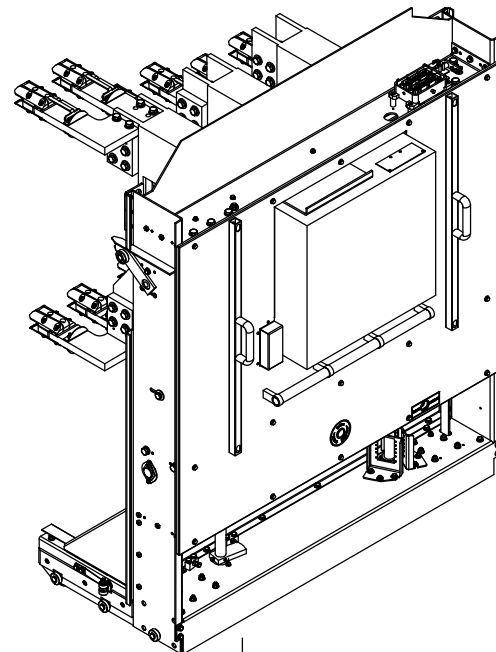

Remarks:

The dimensions in brackets (...) are just for information
The dimensions in round frame (...) are functional dimensions with tolerances

AEG 4000A Circuit breaker

Oberflächenbehandlung - Surface Protection		Zulässige Abweichung für Maße ohne Toleranzangabe - General Tolerance		Oberfläche - Surface DIN ISO 1302		Maßstab - Scale 1:8		Masse - Weight - kg	
-		DIN ISO 2768 - mK		12,5		-		-	
				Date		Name		Benennung - Description	
				Procc. 2011-10-26		M. Kuntke		Fahrwagen kpl. Siemens 3AH3; 4,16kV; 4000A	
				Check -		-		Switch truck, compl. Siemens 3AH3; 4,16kV; 4000A	
				Norm					
c Teile		21.09.2015 Kuntke		Schutzvermerk nach DIN 34 beachten!		Observe protection mark according to DIN 34!		Zeichnungsnummer - Drawing No.	
b Tolerances		02.09.2014 Kuntke						Blatt - Page	
a Schriftfeld		08.04.2014 Herz						025-00-000-0201c	
Status		Modifikation		Date		Name		Ersatz für - Substitute for:	
						SIEMENS		A2	