

Truck shown in test position

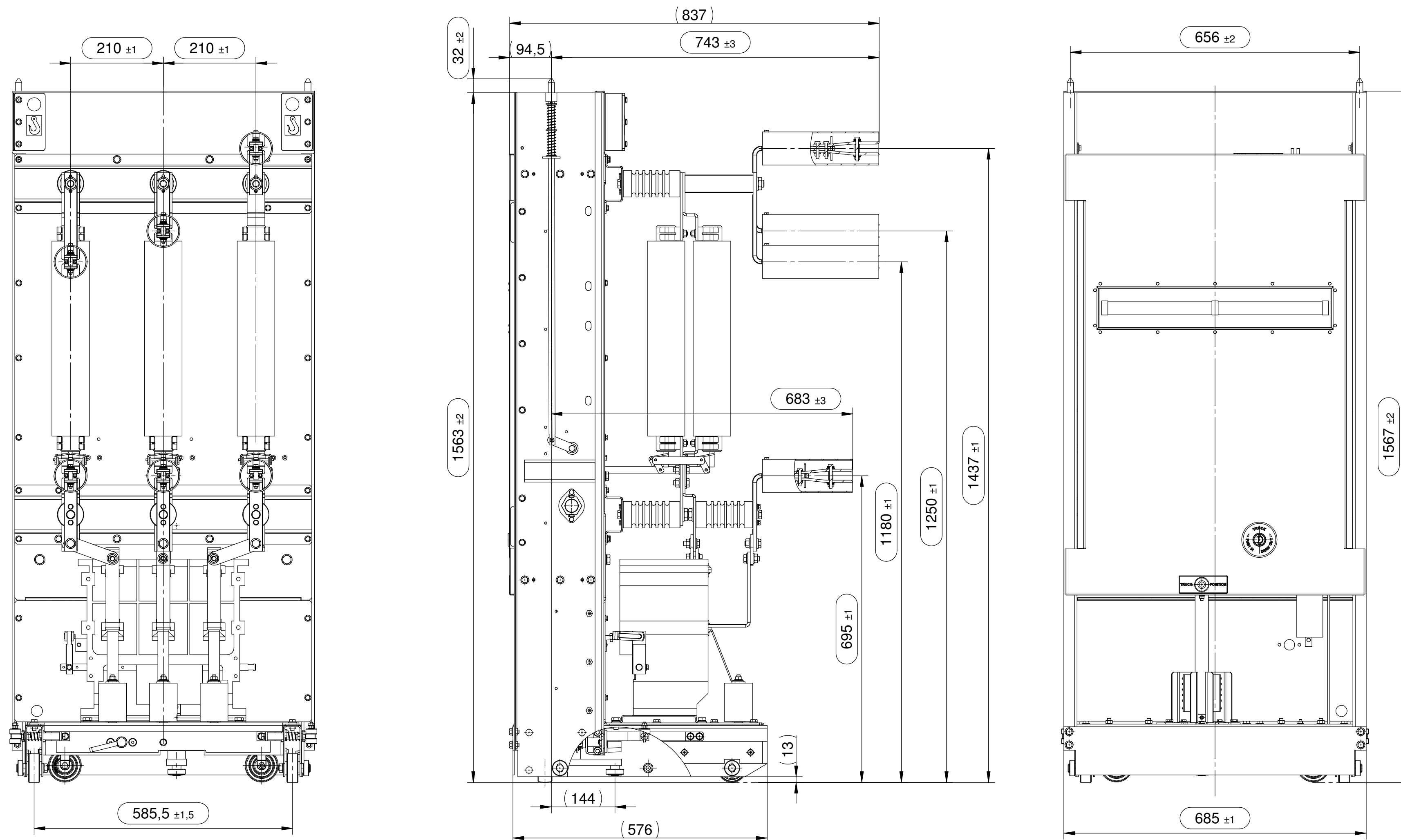

1 : 15

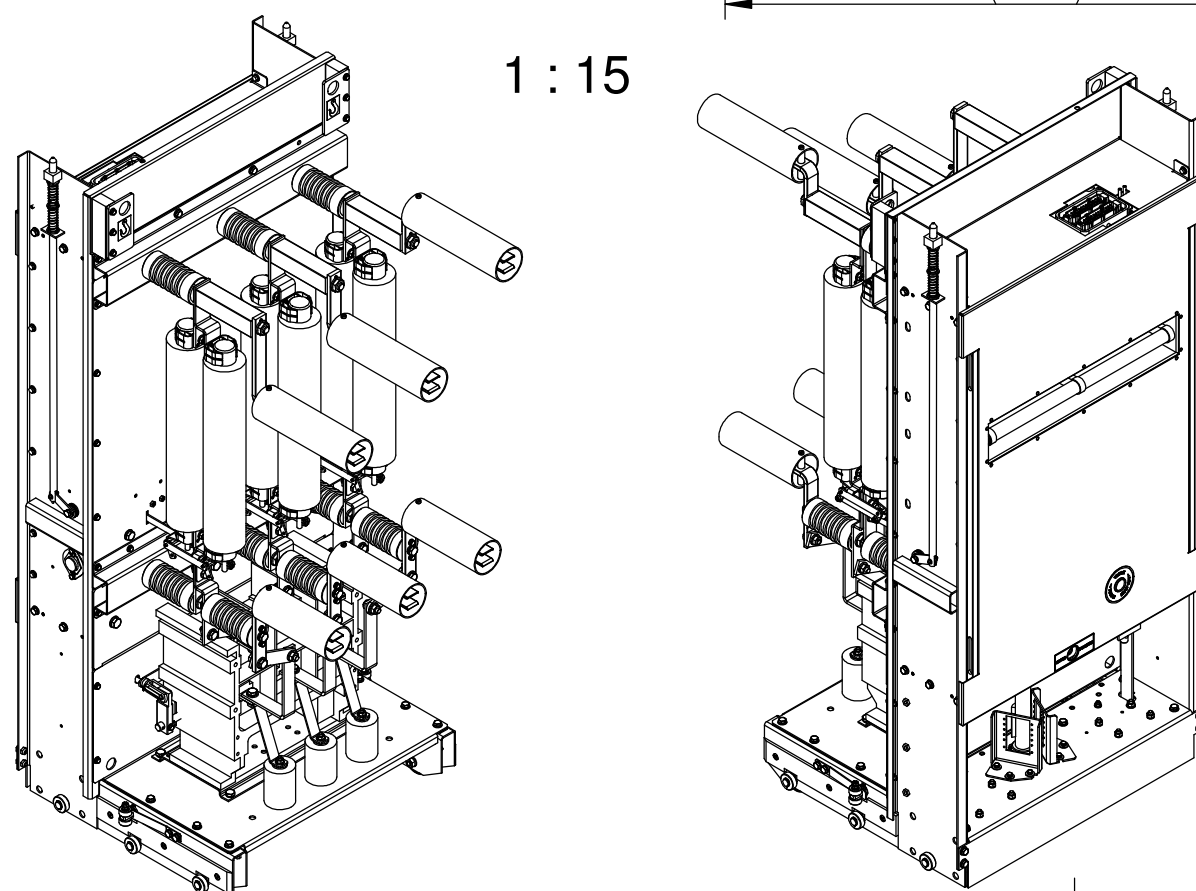

Remarks:

The dimensions in brackets (...) are just for information
The dimensions in round frame (...) are functional dimensions with tolerances

Oberflächenbehandlung - Surface Protection		Zulässige Abweichung für Maße ohne Toleranzangabe - General Tolerance		Oberfläche - Surface		Maßstab - Scale 1:7		Masse - Weight - kg	
-		DIN ISO 2768 - mK		DIN ISO 1302		-		-	
				Date		Name		Benennung - Description	
				Procc. 2012-01-31		M. Kuntke		Fahrwagen kpl. Siemens 3TL8-Sicherung	
				Check -		-		Switch truck, compl. Siemens 3TL8-Backup	
				Norm		-			
c Teile		21.09.2015 Kuntke		Schutzvermerk nach DIN 34 beachten!		Zeichnungsnummer - Drawing No.		Blatt - Page	
b Tolerances		02.09.2014 Kuntke		Observe protection mark according to DIN 34!		025-00-000-0203c		1	
a Pos.		09.04.2014 Herz							
Status		Modifikation		Date		Name		Ersatz für - Substitute for:	
						SIEMENS		A2	